

HeatForm® the in-ground panel pool that doesn't cost the Earth

Manufactured in the UK with insulation from 100% recycled PET plastic bottles, HeatForm's in-ground pools are entirely flexible, allowing unlimited lengths and widths. With three height options, option to suit all ages and abilities.

Our in-ground pools are quick and easy to install, whatever the weather. HeatForm panel pool systems use less concrete than more traditional pool builds, as only the pool floor needs to be concreted and not the walls. As well as helping the environment, this decreases installation time and reduces on-site disruption.

A 10m x 5m pool can have its walls erected within a day and this is not weather dependant. The panels are secured into place and backfilled, allowing completion time in a matter of weeks. Pool flow and return filtration plus LED lights can be easily added where you need them, using the pre-positioned recesses.

HeatForm panel pools are suitable for both indoor and outdoor installations, whether a garden, a patio, in a building or a commercial setting. Choose HeatForm and make your dream pool a reality, putting exercise, fun and relaxation within easy reach of your lifestyle and budget.

Why HeatForm?

- A HeatForm insulated pool can reduce your pool heating costs by up to 50% compared with a standard concrete pool
- Wall depth options: 0.9m, 1.2m and 1.5m
- No limitations to the pool width or length
- Quick - 10m x 5m pool walls are typically completed in one day
- Easy positioning of flow and return fittings in the panel pre-positioned openings
- HeatForm pool panels comply with the Part-L building regulations regarding U-Values requirements.
- Made in Devon, UK



"I couldn't believe how quickly the pool took to complete and that the family were able to enjoy it much sooner than I'd ever expected. It looks great and the Rollo Solar slatted cover gives it a certain je ne sais quoi!"

Miss Gray, HeatForm in-ground pool owner, 2019



Benefits of a Heatform panel pool

- Eco-friendly panel pool system, insulated with 100% recycled PET plastic bottles
- Reduces heating costs by up to 50%
- Modular construction allowing easy access to tight spaces such as basement builds
- No need for cranes lifts, the largest 2.5m panel weighs only 65 kgs
- Smooth clean wall panels ready for lining
- Fast and efficient installation in any weather
- Pre-positioned recesses for filtration and light fittings
- Manufactured in Devon UK, reducing the transportation carbon footprint

Have you seen our other range of energy saving products?

The latest technology from the Zodiac Pool Care range of swimming pool products including; ZS500 air source heat pumps, FloPro variable speed pumps, Magnapool the magnesium based hydroxination system and RGBW LED lighting to name a few.

Finally to secure and insulate the pool, top it off with a Rollo™ Solar automatic solar gain pool cover, which can increase the pool temperature by 3°C on a sunny day. Open and close the pool with the click of a button adding another level of elegance and security** to your pool.

**The use of handrails will be required to support the cover if it is to be used as a safety cover



ROLLO[®]
SOLAR
DESIGN · POOL · COVER



 **ZODIAC[®]**



 **MagnaPool[™]**
Mineral Pool Science



HeatForm® the above-ground panel pool that doesn't cost the Earth

Manufactured in Devon, UK with insulation made from 100% recycled PET plastic bottles, HeatForm's above-ground pools are entirely flexible, available in unlimited lengths and widths and with three height options, there is an option to suit all ages and abilities.

Our above-ground pools are quick and easy to install, allowing you to put a pool in a garden, basement or building where an in-ground pool would not always be possible.

A steel support system surrounds the panels creating a strong and sturdy structure, which is bolted to a concrete floor slab. Adjustable elements are built into the design to remove alignment issues and ensure a perfect finish to your pool project.

Each pool can be customised with a pool liner of your choice and you can select from our wide range of Zodiac pool products (pumps, robotic pool cleaners, heating and water treatment solutions) to complete the ultimate pool package.

Bespoke extras include external cladding kits to ensure that the pool reflects your own personal taste and fits with the surrounding environment. Counter current exercise jets can also add an extra fitness element to your pool. Our specially developed end panel can be added into the pool build to incorporate the HF SwimJet*.

* Adapted end panels are also available for most other brands of exercise jets

Why HeatForm?

- A HeatForm insulated pool can reduce your pool heating costs by up to 50% compared with a standard concrete pool
- Wall depth options: 0.9m, 1.2m and 1.5m
- No limitations to the pool width or length
- A 10m x 5m wall section is typically completed in one day
- Easy positioning of flow and return fittings in the panel pre-positioned openings
- HeatForm pool panels comply with the Part-L building regulations regarding U-Values

"We chose a HeatForm above-ground insulated panel system to replace an ageing school pool as it was simple and quick to install and the insulated panels will provide significant energy cost reductions in the future. The school were particularly impressed with the eco-friendly nature of the panels on top of the heating benefits they will achieve. We received great customer service from Lighthouse Pools and would highly recommend the HeatForm pool system"

Steve Whiteley, Aquafun Sheffield.

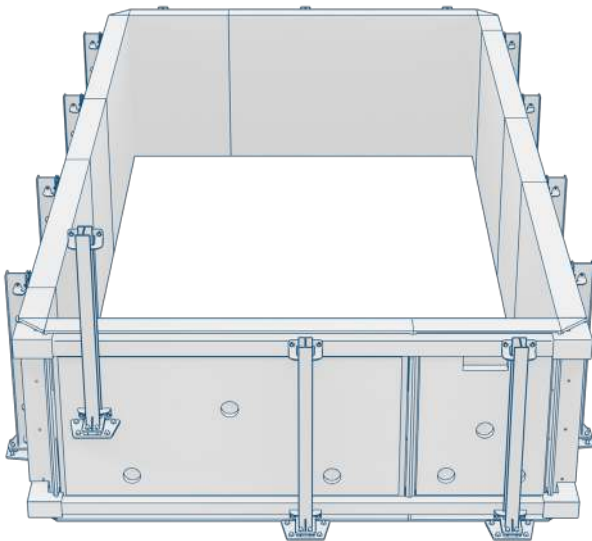
**Benefits of a HeatForm above-ground panel pool**

- Eco-friendly panel pool system, insulated with 100% recycled PET plastic bottles
- Reduces heating costs by up to 50%
- Modular construction allowing easy access to tight spaces such as basement builds and awkward sloping gardens
- Easily adjusted, galvanised steel support frame
- Smooth clean wall panels giving a professional pool build ready for lining
- Fast and efficient installation
- Pre-positioned recesses for filtration and light fittings
- Manufactured in Devon, UK, reducing your transportation carbon footprint

To further enhance your swimming experience, optional extras such as MagnaPool™ can be easily added as an option. An exclusive magnesium-based water treatment system that helps soothe aches and pains, caring for the skin and hair and easing muscular problems.

To secure and insulate your pool, why not top it off with a Rollo™ Solar automatic solar gain pool cover, which can increase the pool temperature by 3°C on a sunny day. Open and close the pool with the click of a button adding another level of elegance and security* to the pool.

**The use of handrails will be required to support the cover if it is to be used as a safety cover

